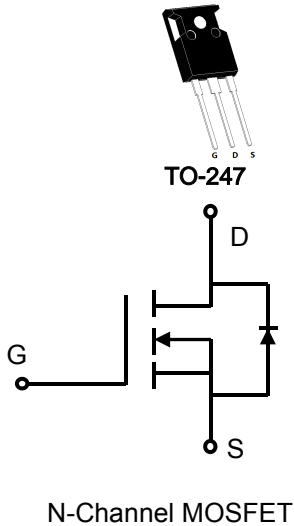

## N-channel 650V, 47A, 0.07Ω Power MOSFET

<p><b>Description</b></p> <p>BT Power MOSFET is fabricated using advanced super junction technology. The resulting device has extremely low on resistance, making it especially suitable for applications which require superior power density and outstanding efficiency.</p> <p><b>Features</b></p> <ul style="list-style-type: none"> <li>◆ Ultra low <math>R_{DS(on)}</math></li> <li>◆ Ultra low gate charge (typ. <math>Q_g = 87\text{nC}</math>)</li> <li>◆ 100% UIS tested</li> <li>◆ RoHS compliant</li> </ul> <p><b>Applications</b></p> <ul style="list-style-type: none"> <li>◆ Power factor correction (PFC).</li> <li>◆ Switched mode power supplies (SMPS).</li> <li>◆ Uninterruptible power supply (UPS).</li> </ul>	<p><b>Product Summary</b></p> <table> <tr> <td><math>V_{DS} @ T_{j,max}</math></td> <td>700V</td> </tr> <tr> <td><math>R_{DS(on),max}</math></td> <td>0.070Ω</td> </tr> <tr> <td><math>I_{DM}</math></td> <td>141A</td> </tr> <tr> <td><math>Q_{g,typ}</math></td> <td>87nC</td> </tr> </table> <div style="text-align: center;">  <p>TO-247</p> <p>N-Channel MOSFET</p> </div>	$V_{DS} @ T_{j,max}$	700V	$R_{DS(on),max}$	0.070Ω	$I_{DM}$	141A	$Q_{g,typ}$	87nC
$V_{DS} @ T_{j,max}$	700V								
$R_{DS(on),max}$	0.070Ω								
$I_{DM}$	141A								
$Q_{g,typ}$	87nC								

### Absolute Maximum Ratings

Parameter	Symbol	Value	Unit
Drain-Source Voltage	$V_{DSS}$	650	V
Continuous drain current ( $T_C = 25^\circ\text{C}$ )	$I_D$	47	A
( $T_C = 100^\circ\text{C}$ )		30	A
Pulsed drain current <sup>1)</sup>	$I_{DM}$	141	A
Gate-Source voltage	$V_{GSS}$	$\pm 30$	V
Avalanche energy, single pulse <sup>2)</sup>	$E_{AS}$	1200	mJ
Power Dissipation TO-247 ( $T_C = 25^\circ\text{C}$ )	$P_D$	290	W
- Derate above $25^\circ\text{C}$		2.32	W/ $^\circ\text{C}$
Operating and Storage Temperature Range	$T_J, T_{STG}$	-55 to +150	$^\circ\text{C}$
Continuous diode forward current	$I_S$	47	A
Diode pulse current	$I_{S,pulse}$	141	A

### Thermal Characteristics TO-247

Parameter	Symbol	Value	Unit
Thermal Resistance, Junction-to-Case	$R_{\theta JC}$	0.43	$^\circ\text{C}/\text{W}$
Thermal Resistance, Junction-to-Ambient	$R_{\theta JA}$	60	$^\circ\text{C}/\text{W}$
Soldering temperature, wavesoldering only allowed at leads. (1.6mm from case for 10s)	$T_{sold}$	260	$^\circ\text{C}$

## Package Marking and Ordering Information

Device	Device Package	Marking	Units/Tube	Units/Reel
BTW65R070A	TO-247	BTW65R070	30	

## Electrical Characteristics

$T_c = 25^\circ\text{C}$  unless otherwise noted

Parameter	Symbol	Test Condition	Min.	Typ.	Max.	Unit
<b>Static characteristics</b>						
Drain-source breakdown voltage	$BV_{DSS}$	$V_{GS}=0\text{ V}, I_D=0.25\text{ mA}$	650	-	-	V
Gate threshold voltage	$V_{GS(th)}$	$V_{DS}=V_{GS}, I_D=0.25\text{ mA}$	2.5	3	5	V
Drain cut-off current	$I_{DSS}$	$V_{DS}=650\text{ V}, V_{GS}=0\text{ V},$ $T_j = 25^\circ\text{C}$ $T_j = 125^\circ\text{C}$	-	-	5	$\mu\text{A}$
			-	10	-	
Gate leakage current, Forward	$I_{GSSF}$	$V_{GS}=30\text{ V}, V_{DS}=0\text{ V}$	-	-	100	nA
Gate leakage current, Reverse	$I_{GSSR}$	$V_{GS}=-30\text{ V}, V_{DS}=0\text{ V}$	-	-	-100	nA
Drain-source on-state resistance	$R_{DS(on)}$	$V_{GS}=10\text{ V}, I_D=23.5\text{ A}$ $T_j = 25^\circ\text{C}$ $T_j = 150^\circ\text{C}$	-	-	-	$\Omega$
			-	0.062	0.070	
			-	0.16	-	
<b>Dynamic characteristics</b>						
Input capacitance	$C_{iss}$	$V_{DS} = 100\text{ V}, V_{GS} = 0\text{ V},$ $f = 250\text{ kHz}$	-	4560	-	$\text{pF}$
Output capacitance	$C_{oss}$		-	154	-	
Reverse transfer capacitance	$C_{rss}$		-	5.1	-	
Turn-on delay time	$t_{d(on)}$	$V_{DD} = 400\text{ V}, I_D = 23.5\text{ A}$ $R_G = 10\Omega, V_{GS}=10\text{ V}$	-	28.3	-	ns
Rise time	$t_r$		-	12.9	-	
Turn-off delay time	$t_{d(off)}$		-	186.5	-	
Fall time	$t_f$		-	13.5	-	
<b>Gate charge characteristics</b>						
Gate to source charge	$Q_{gs}$	$V_{DD}=480\text{ V}, I_D=23.5\text{ A},$ $V_{GS}=0\text{ to }10\text{ V}$	-	24	-	nC
Gate to drain charge	$Q_{gd}$		-	31.24	-	
Gate charge total	$Q_g$		-	87	-	
Gate plateau voltage	$V_{plateau}$		-	5.5	-	V
<b>Reverse diode characteristics</b>						
Diode forward voltage	$V_{SD}$	$V_{GS}=0\text{ V}, I_F=23.5\text{ A}$	-	1.0	-	V
Reverse recovery time	$t_{rr}$	$V_R=400\text{ V}, I_F=19.4\text{ A},$ $dI_F/dt=100\text{ A}/\mu\text{s}$	-	191	-	ns
Reverse recovery charge	$Q_{rr}$		-	1.81	-	$\mu\text{C}$
Peak reverse recovery current	$I_{rrm}$		-	19	-	A

### Notes:

- Limited by maximum junction temperature, maximum duty cycle is 0.75.
- $I_{AS} = 8\text{ A}, V_{DD} = 60\text{ V},$  Starting  $T_j = 25^\circ\text{C}.$

Electrical Characteristics Diagrams

Figure 1. On-Region Characteristics

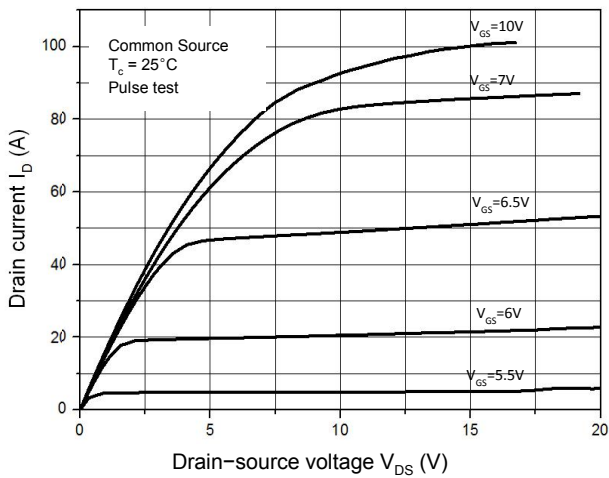

Figure 2. Transfer Characteristics

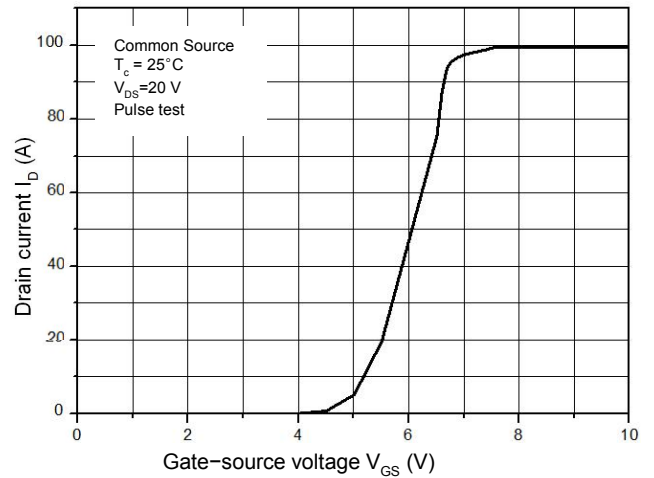

Figure 3. On-Resistance Variation vs. Drain Current

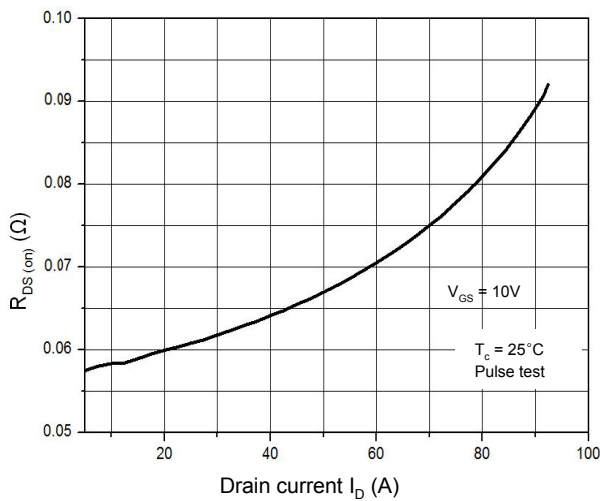

Figure 4. Threshold Voltage vs. Temperature

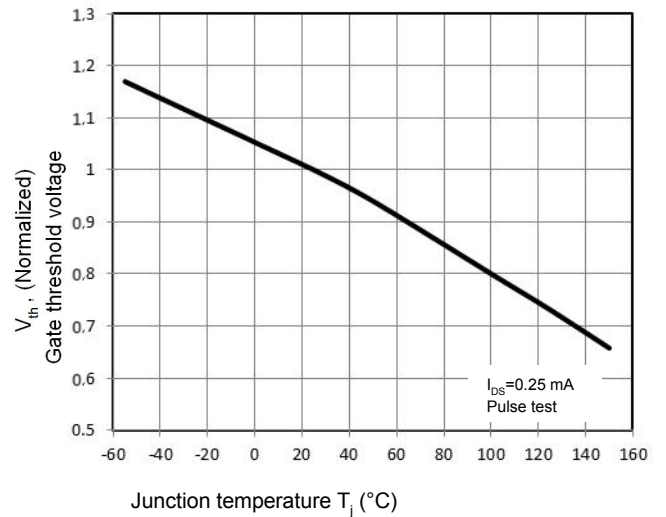

Figure 5. Breakdown Voltage vs. Temperature

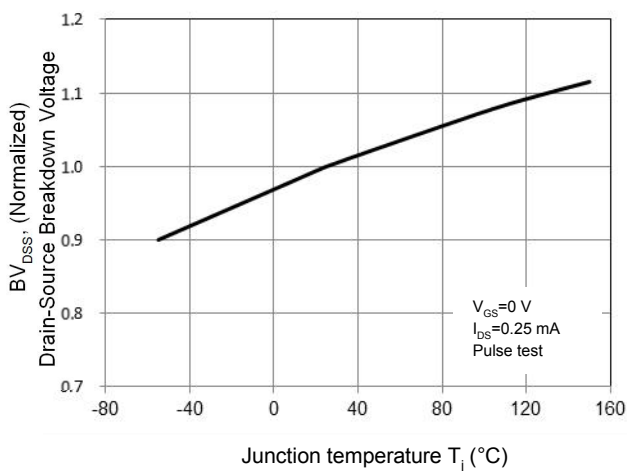

Figure 6. On-Resistance vs. Temperature

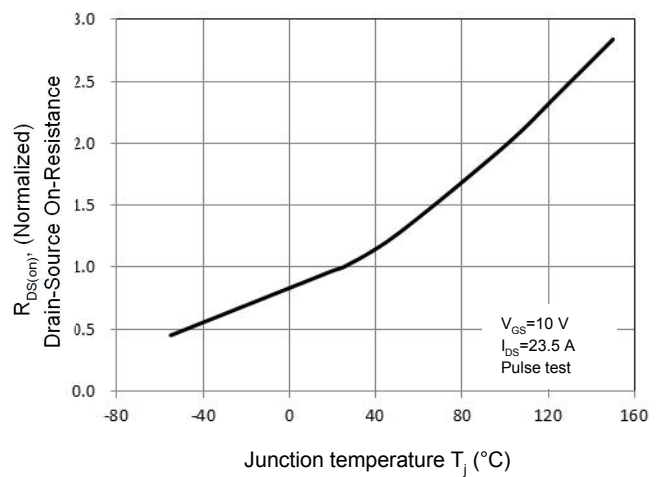

Figure 7. Capacitance Characteristics

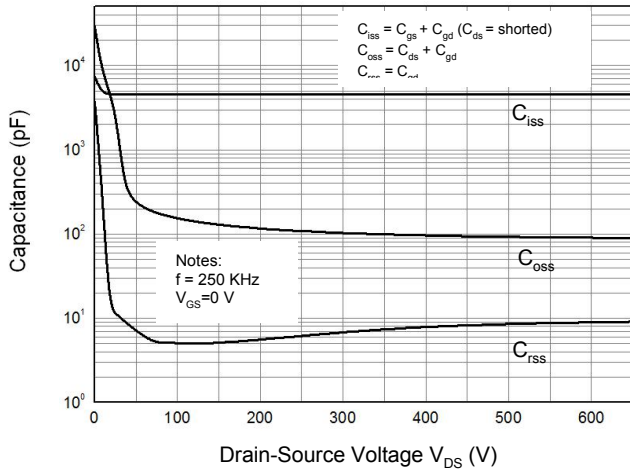

Figure 8. Gate Charge Characterist

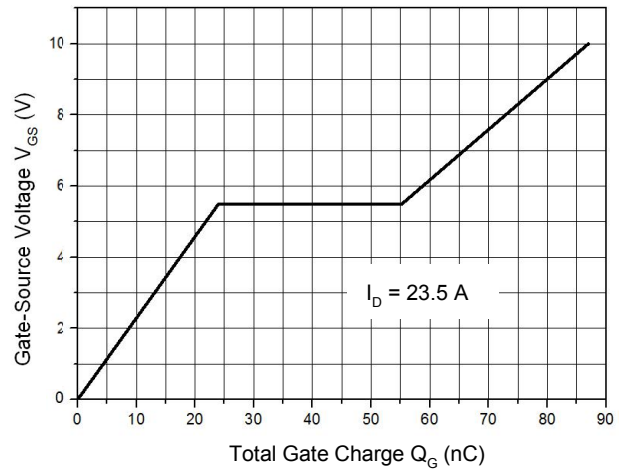

Figure 9. Maximum Safe Operating Area

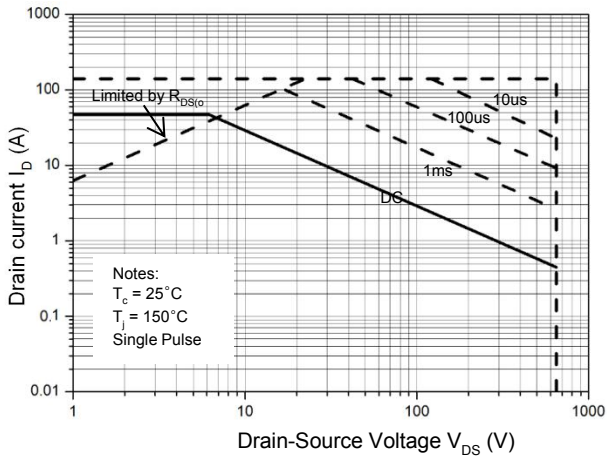

Figure 10. Power Dissipation vs. Temperature

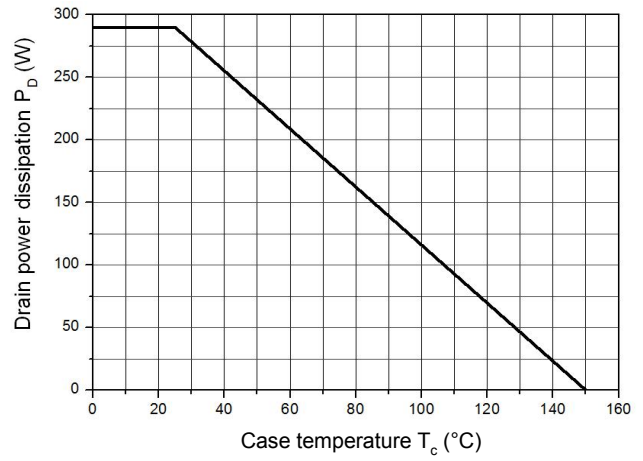
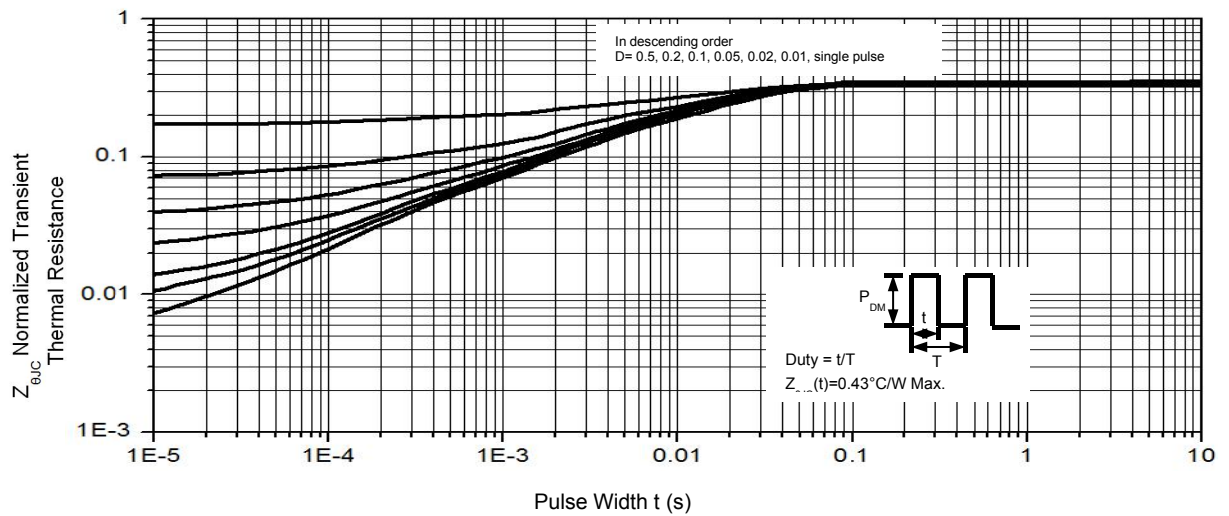
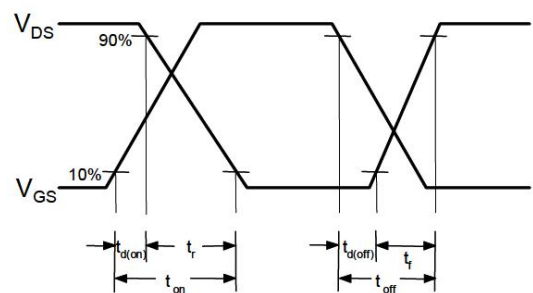
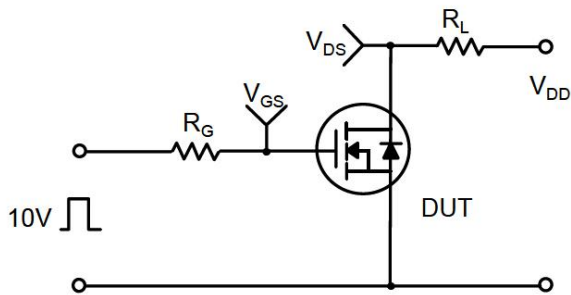
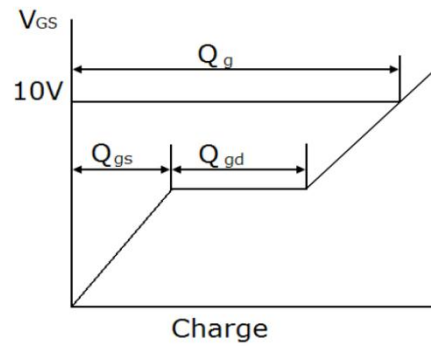
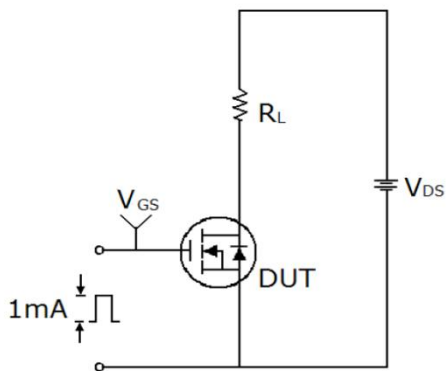

Figure 11. Transient Thermal Response Curve



Gate Charge Test Circuit & Waveform



Unclamped Inductive Switching Test Circuit & Waveforms

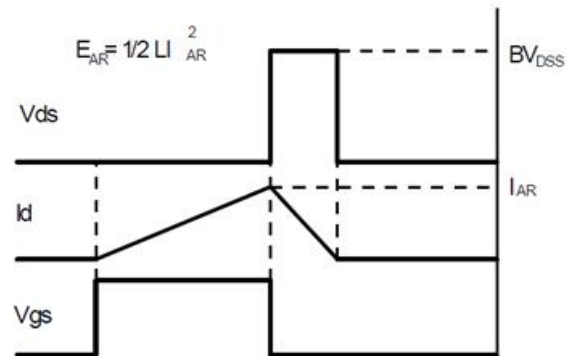
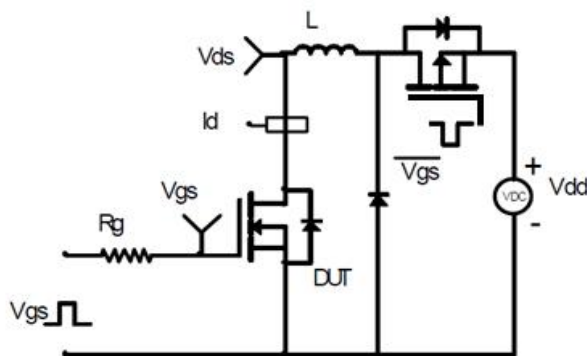

Mechanical Dimensions for TO-247

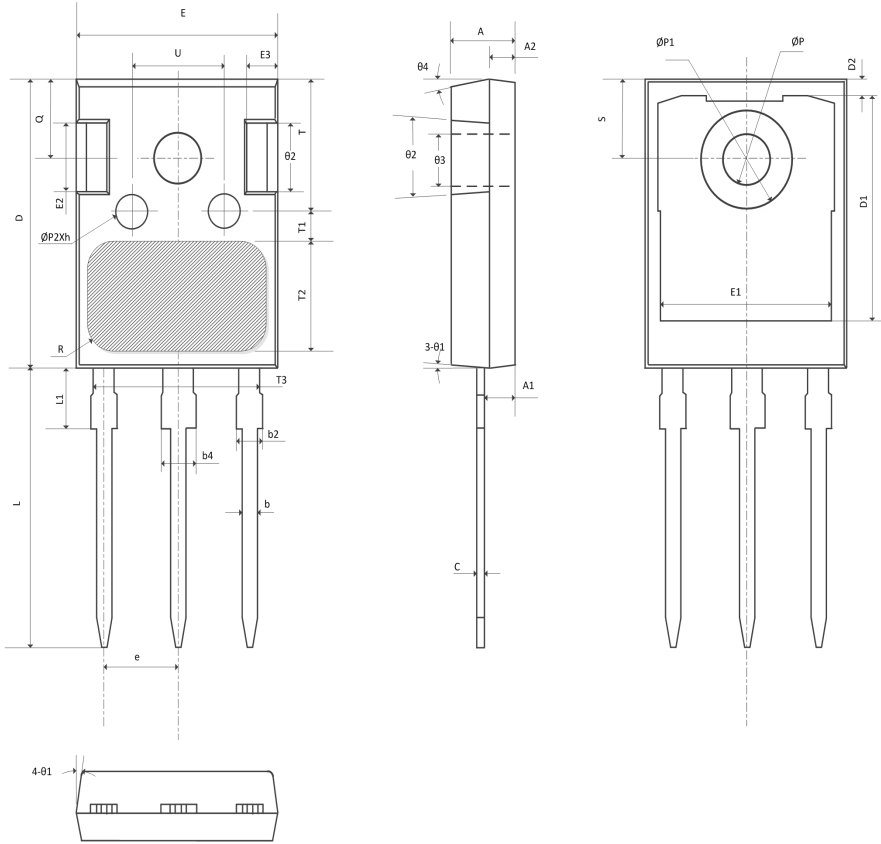

SYMBOL	mm		
	MIN	NOM	MAX
A	4.90	5.00	5.10
A1	2.31	2.41	2.51
A2	1.90	2.00	2.10
b	1.16	1.21	1.26
b2	1.96	2.01	2.06
b4	2.96	3.01	3.06
c	0.59	0.61	0.66
D	20.90	21.00	21.10
D1	16.25	16.55	16.85
D2	1.05	1.20	1.35
E	15.70	15.80	15.90
E1	13.10	13.30	13.50
E2	4.90	5.00	5.10
E3	2.40	2.50	2.60
e	5.44BSC		
h	0.05	0.10	0.15
L	19.80	19.92	20.10
L1	—	—	4.30
ØP	3.50	3.60	3.70
ØP1	—	—	7.30
ØP2	2.40	2.50	2.60
Q	5.60	5.80	6.00
S	6.15BSC		
R	0.50REF		
T	9.80	—	10.20
T1	1.65REF		
T2	8.00REF		
T3	12.80REF		
U	6.00	—	6.40
Ø1	6°	7°	8°
Ø2	4°	5°	6°
Ø3	1°	—	1.5°
Ø4	14°	15°	16°

TO-247 Part Marking Information

