

# BTX20120Q2

## 1200V Silicon Carbide Diode

### Features

- 1200-Volt Schottky Rectifier
- Shorter recovery time
- High-speed switching possible
- High-Frequency Operation
- Temperature-Independent Switching Behavior
- Extremely Fast Switching
- Positive Temperature Coefficient on VF

### Benefits

- Higher safety margin against overvoltage
- Improved efficiency all load conditions
- Increased efficiency compared to Silicon Diode alternatives
- Reduction of Heat Sink Requirements
- Parallel Devices Without Thermal Runaway
- Essentially No Switching Losses

### Applications

- Switch Mode Power Supplies
- Power Factor Correction
- Motor Drives
- HID Lighting

### Package

Type : TO-247-2Lead

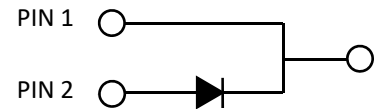
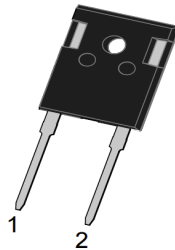

### Absolute Maximum Ratings

$T_c = 25^\circ\text{C}$  unless otherwise noted

Symbol	Parameter	MSH20120V1	Units
VRRM	Repetitive Peak Reverse Voltage	1200	V
VRSM	Surge Peak Reverse Voltage	1200	V
VDC	DC Blocking Voltage	1200	V
IF	Continuous Forward Current @ $T_c=25^\circ\text{C}$ @ $T_c=125^\circ\text{C}$ @ $T_c=137^\circ\text{C}$	53 27 20	A
IFRM	Repetitive Peak Forward Surge Current @ $T_c=25^\circ\text{C}$ , $t_P = 10$ ms, Half Sine Wave	100	A
IFSM	Non-Repetitive Peak Forward Surge Current @ $T_c=25^\circ\text{C}$ , $t_P = 10$ ms, Half Sine Wave	140	A
Ptot	Power Dissipation @ $T_c=25^\circ\text{C}$ @ $T_c=110^\circ\text{C}$	258 112	W
$T_J, T_{stg}$	Operating Junction and Storage Temperature	-55 to +175	$^\circ\text{C}$

## Electrical Characteristics

$T_C = 25^\circ \text{C}$  unless otherwise noted

Symbol	Test Conditions	Test Conditions	Min	Typ	Max	Unit
VF	Forward Voltage(Per Lag)	IF=10A, TC=25° C IF=10A, TC=175° C	-	1.5 2.2	1.8 3.0	V
IR	Reverse Current	VR=1200V, TC=25° C VR=1200V, TC=175° C	-	2 20	5 40	μA
QC	Total Capacitive Charge	VR =600V, IF =10A TJ = 25° C $Q_c = \int_0^{V_r} C (V) dv$	-	95	-	nC
C	Total Capacitance	VR =0V, TJ = 25° C, f=1MHz VR =400V, TJ = 25° C, f=1MHz VR =600V, TJ = 25° C, f=1MHz	-	2010 120 97	-	pF
EC	Capacitance Stored Energy	VR=600V	-	28.6	-	μJ

## Thermal Characteristics

Symbol	Parameter	Typ	Unit
RθJC	Thermal Resistance from Junction to Case	0.58	°C/W

## Typical Characteristics

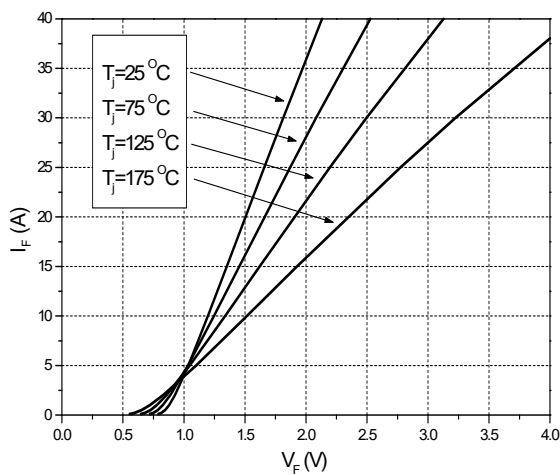

Figure 1. Forward Characteristics

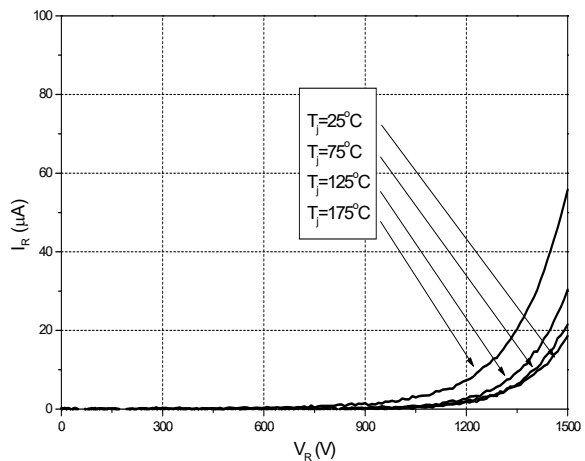

Figure 2. Reverse Characteristics

# Typical Characteristics

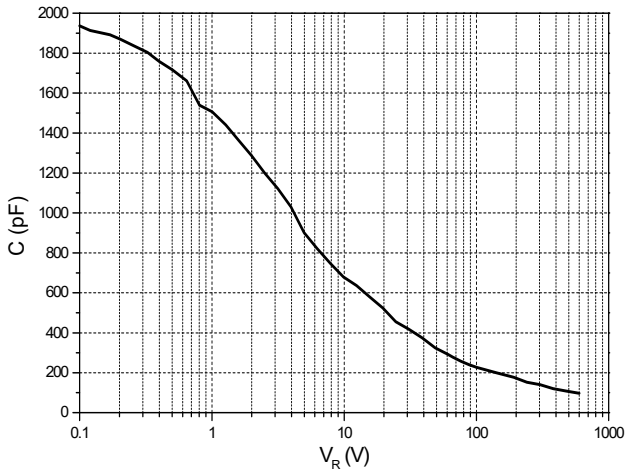

Figure 3. Capacitance vs. Reverse Voltage

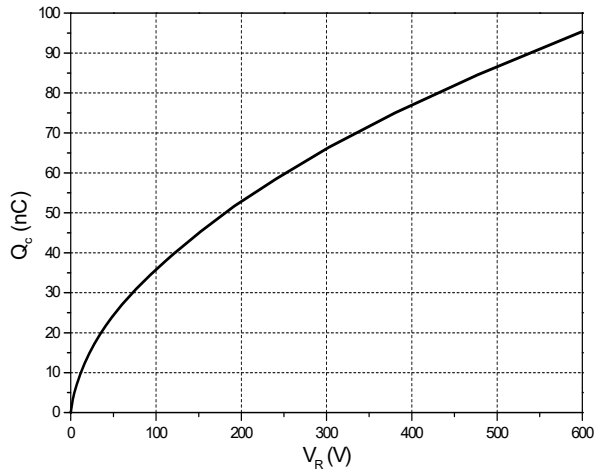

Figure 4. Total Capacitance Charge vs. Reverse Voltage

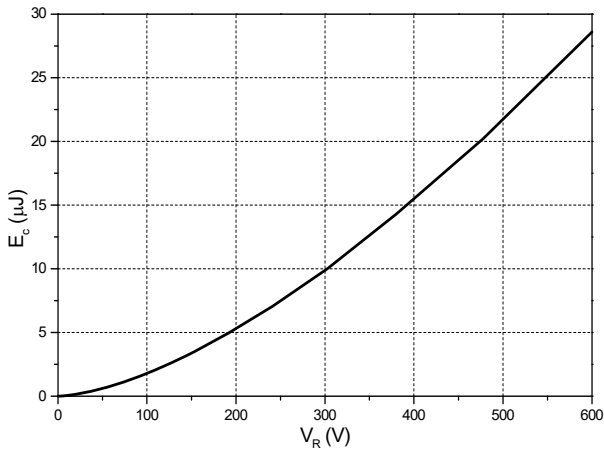

Figure 5. Capacitance Stored Energy

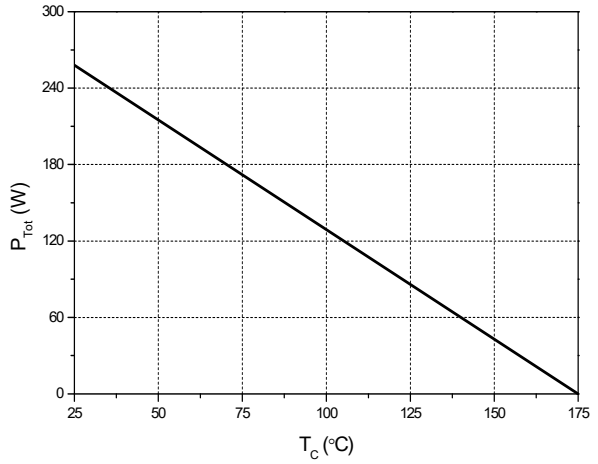

Figure 6. Power Derating

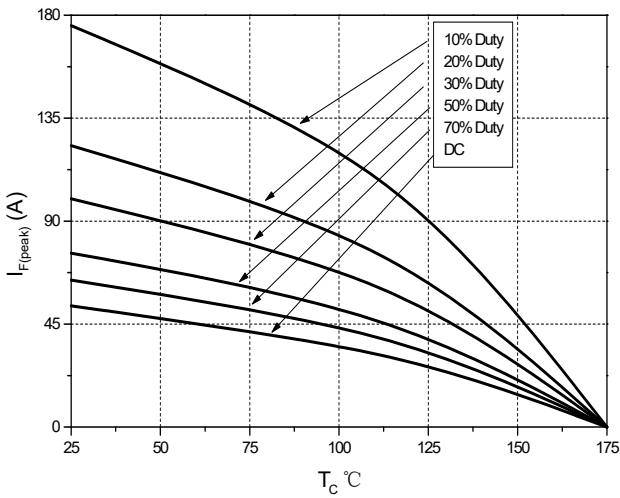
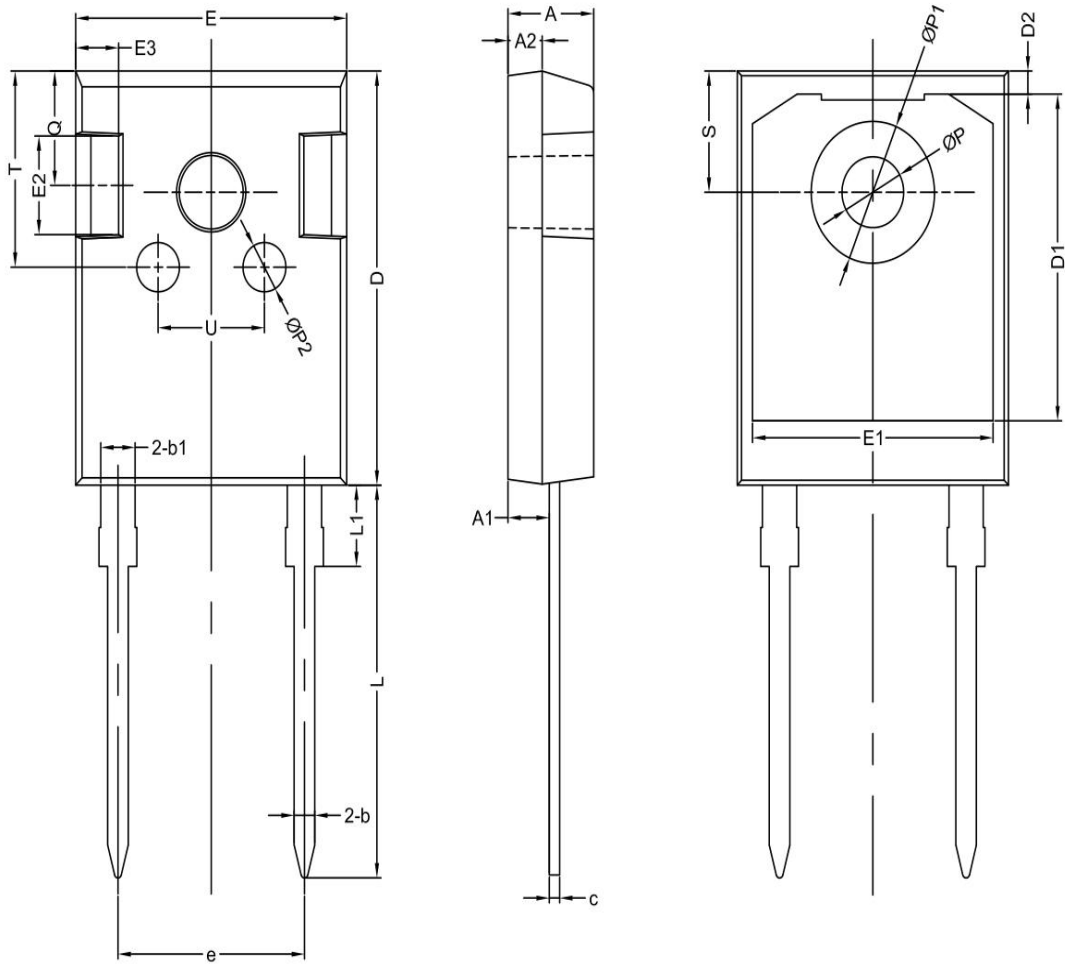

Figure 7. Current Derating



SYMBOL	Mechanical Dimensions/mm			SYMBOL	Mechanical Dimensions/mm			SYMBOL	Mechanical Dimensions/mm		
	MIN	NOM	MAX						MIN	NOM	MAX
A	4.80	5.00	5.20	D1	-	16.55	-	L1	-	4.13	-
A1	2.21	2.41	2.61	D2	-	1.17	-	Ø P	3.4	3.6	3.8
A2	1.90	2.00	2.10	E	15.50	15.80	16.10	Ø P1	-	7.19	-
b	1.05	1.20	1.35	E1		14.02		Ø P2	-	2.50	-
b1	-	2.00	-	E2		5.0		Q	-	5.8	-
c	0.55	0.60	0.75	e	10.88			S	6.00	6.15	6.25
D	20.65	21.00	21.20	L	19.22	19.92	20.42	T	-	10.0	-

NOTE:

1.The plastic package is not marked as smooth surfaceRa=0.1;Subglossy surfaceRa=0.8

2.Undeclared tolerance ± 0.15,Unmarked filletRmax=0.25

NAME	TO-247-2L OUTLINE	UNIT	mm	DESIGNED	Shawn	THIRD ANGLE SYSTEM
DWGNO		PAGE	1 OF 1	CHECKED		
VERSION	Ver1.0	ISSUE DATE		APPROVED		